



# KLINGER BALLOSTAR® KHE

2-piece ball valves  
DN 15 – 200 (1/2" – 8")



# KLINGER FLUID CONTROL

Today for tomorrow

As a subsidiary of the KLINGER Group, KLINGER Fluid Control has been developing, manufacturing and maintaining high-quality industrial valves at the business location Gumpoldskirchen/Austria for more than 125 years. Via the global distribution and service network, KLINGER Fluid Control offers both standardized and tailored products, services as well as solutions for customers around the globe.

Products from KLINGER Fluid Control are characterized by their high level of reliability as well as by an above average lifecycle at a simultaneously very total cost of ownership (TCO). As a solutions partner, KLINGER Fluid Control creates customer benefits with added value. In this regard, the focus is on the following core competences:



## ENCOMPASSING SERVICE

- » Application expertise
- » Product trainings
- » Fast quotation and order processing
- » Customer-specific special solutions
- » Supply of spare parts
- » Valve maintenance
- » On-site technical support

## INNOVATIVE SOLUTIONS

- » State of the art development tools
- » Product development for different areas of application
- » Customer-specific special solutions
- » Automation solutions
- » Product tests in the company-own technical center
- » A wide range of certificates and approvals

## OPERATIONAL EXCELLENCE

- » Flexible production
- » Transparency in the supply chain
- » Short delivery times
- » ISO 9001 certified quality
- » ISO 14001 as well as EMAS certified environmental management system

trusted. worldwide.

# GREATEST SAFETY

The unique KLINGER sealing system with multiple safeguards

## THE SEALING SYSTEM

- A Stuffing box**

Sealing of the operating stem is achieved by means of a (labyrinth) stuffing box. Only minor contact forces are required for tightness. In this context, the plate spring continuously exerts a contact pressure on the stuffing box – changing temperature and pressure conditions are thus equalized. Virtually maintenance-free, this system is furthermore characterized by a very low setting behavior.
- B Secondary body sealing**

The graphite seal is located on the connection between the body and the flange end piece and supports tightness to the atmosphere. At the same time, it increases protection against leakages in the event of highly fluctuating temperatures and pressure respectively.
- C Diaphragm spring**

The stainless steel elastic sealing element is pre-stressed by a diaphragm spring. With the KFC sealing ring and a K-Flon U-sleeve, it forms the flange-end element of the sealing system in the bore.
- D Sealing ring**

The sealing ring, made of KFC-25, is located directly on the body of the valve and is surrounded on three sides. This prevents the sealing ring from floating in radial direction, against the rear and into the bore.

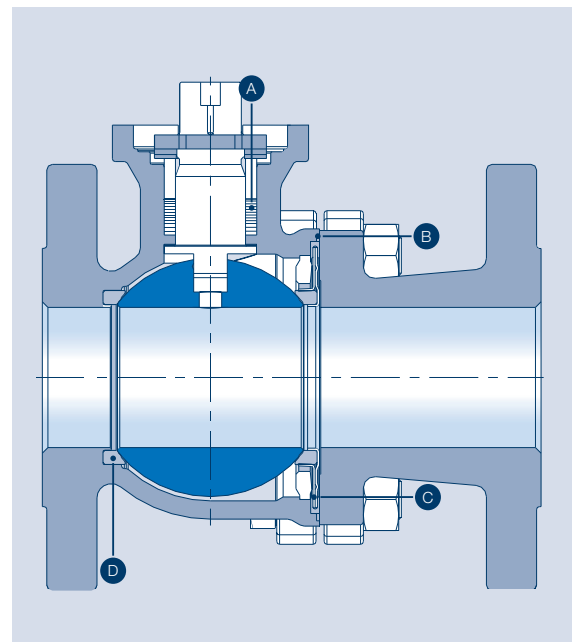

## RECOMMENDED MOUNTING DIRECTION

If the elastic sealing element is located upstream, different forces will come into effect. The pressure of the medium exerts the force  $F_M$  on the ball and on the upstream-side sealing ring (contact force  $F_P$ ). The pre-stress force ( $F_V$ ) also presses the sealing element against the ball. Furthermore, the sealing element is also exposed to the pressure of the medium with the force  $F_{M1}$ . Together, they increase the total force exerted on the ball, and the diaphragm spring is simultaneously relieved of stresses. Thanks to the elasticity of the KLINGER sealing system, two sealing areas are constantly maintained in the bore. Due to the fact that KLINGER recommends this mounting direction as standard, it is additionally marked by an arrow on the body. Pressurization, however, is basically possible in both flow directions.

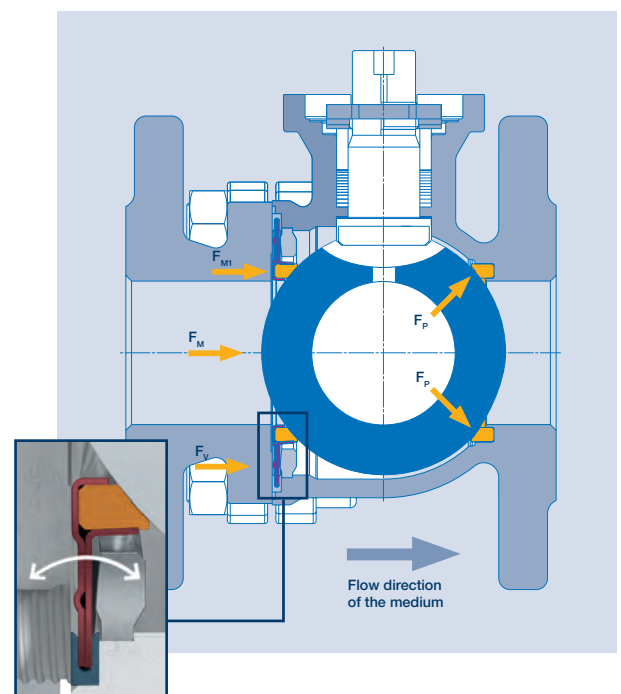

# CONSISTENTLY MODULAR

One product – many applications



## PRODUCT ADVANTAGES

- » Maintenance-free
- » Supports pressurization on both sides
- » Ball with cylindrical full bore
- » Sealing in accordance with EN 12266-1 – leakage rate A
- » Modular selection of system components
- » Fire Safe
- » Antistatic design in accordance with ISO 7121 / EN 1983
- » Subsequent automation possible at any time (top flange in accordance with EN ISO 5211)
- » Optimal spare parts availability (as a result of common parts with Ballostar® KHA)



## SPECIAL TYPES

- » Metal seat for abrasive media
- » Operating stem sealed by O-rings
- » Operating stem extension
- » Oxygen version (oil- and grease-free)
- » Gas version



## PRODUCT DETAILS

PN	16/40, Class 150
DN	15 - 200, ½" - 8"
Housing	Cast steel, stainless steel, special materials upon request
Ball	Stainless steel
Operating Stem	Stainless steel
Temperature	-60 °C to +300 °C
Design	Flanges (short), full bore
Type	Two-piece ball valve

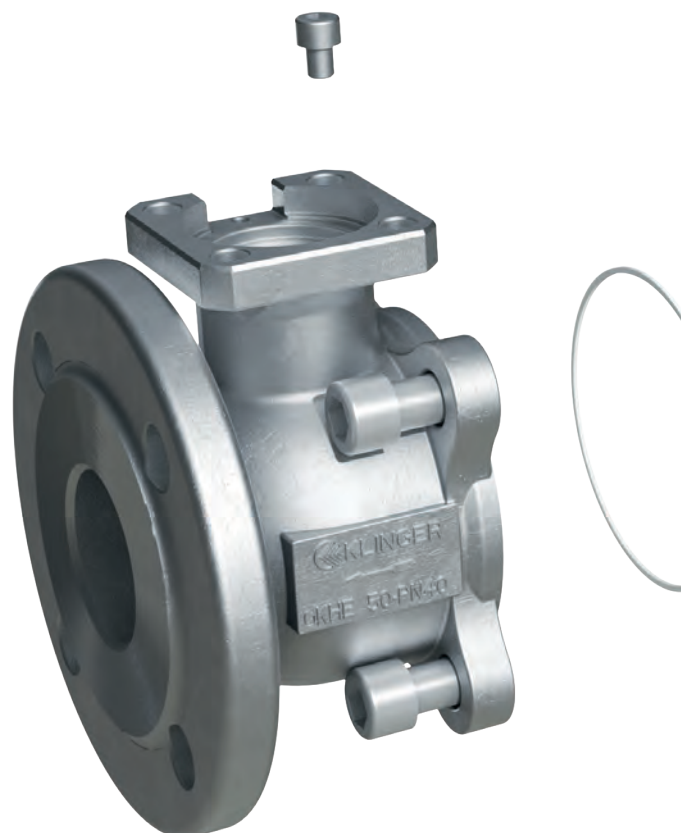

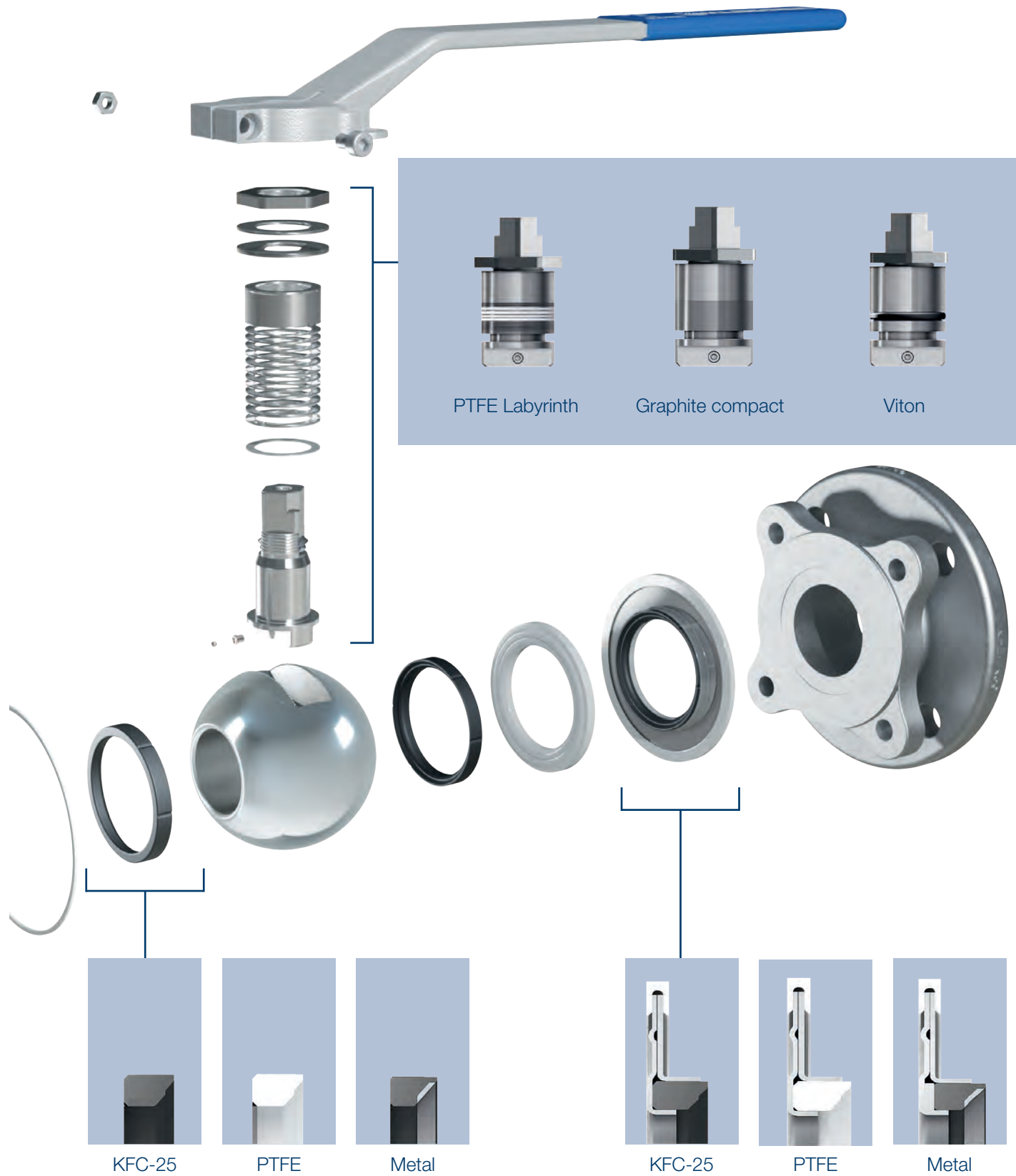

# CERTIFIED QUALITY

## The KLINGER Ballostar® KHE lives up to its promises

In terms of its multiple areas of application, the KLINGER Ballostar® KHE leaves no questions unanswered. This is underlined by numerous third-party inspections and certifications. For operators, this means absolute operational safety with guaranteed tightness.

### » **Standard antistatic**

The KLINGER Ballostar® KHE features antistatic equipment in accordance with EN 1983 as a standard. In this context, an antistatic ball from DN 50 upwards ensures the electrostatic discharge.

### » **Operational safety**

As a standard, the KLINGER Ballostar® KHE comes equipped with a fitting for the installation of a locking device. This negates unintended utilization.

### » **Fire Safe**

As a future-proof product, the KLINGER Ballostar® KHE already meets the high demands of the norm EN ISO 10497 in its standard design. The Fire Safe test was carried out by Lloyd's Register in compliance with the norm.

### » **Valve on the basis of "TA-Luft"**

The requirements of the German Technical Instructions on Air Quality Control in accordance with VDI 2440 have been clearly fulfilled.

### » **Valve with leakage rate A**

The KLINGER Ballostar® KHE meets all the requirements of the norm EN 12266-1 for soft seat sealing elements.

### » **Valve for oxygen service**

The BAM Germany has approved the KLINGER Ballostar® KHE for utilization with oxygen at up to max. 60 °C, max. PN 16.

### » **Valve for natural gas service**

The KLINGER Ballostar® KHE fulfills the requirements of the norm EN 14141 for ball valves with an operating pressure of up to 40 bar.

### » **Valve for gas distribution systems with up to 16 bar**

The KLINGER Ballostar® KHE meets the gas approval requirements in accordance with EN 13774 for gas distribution systems with a permissible operating pressure of up to 16 bar.

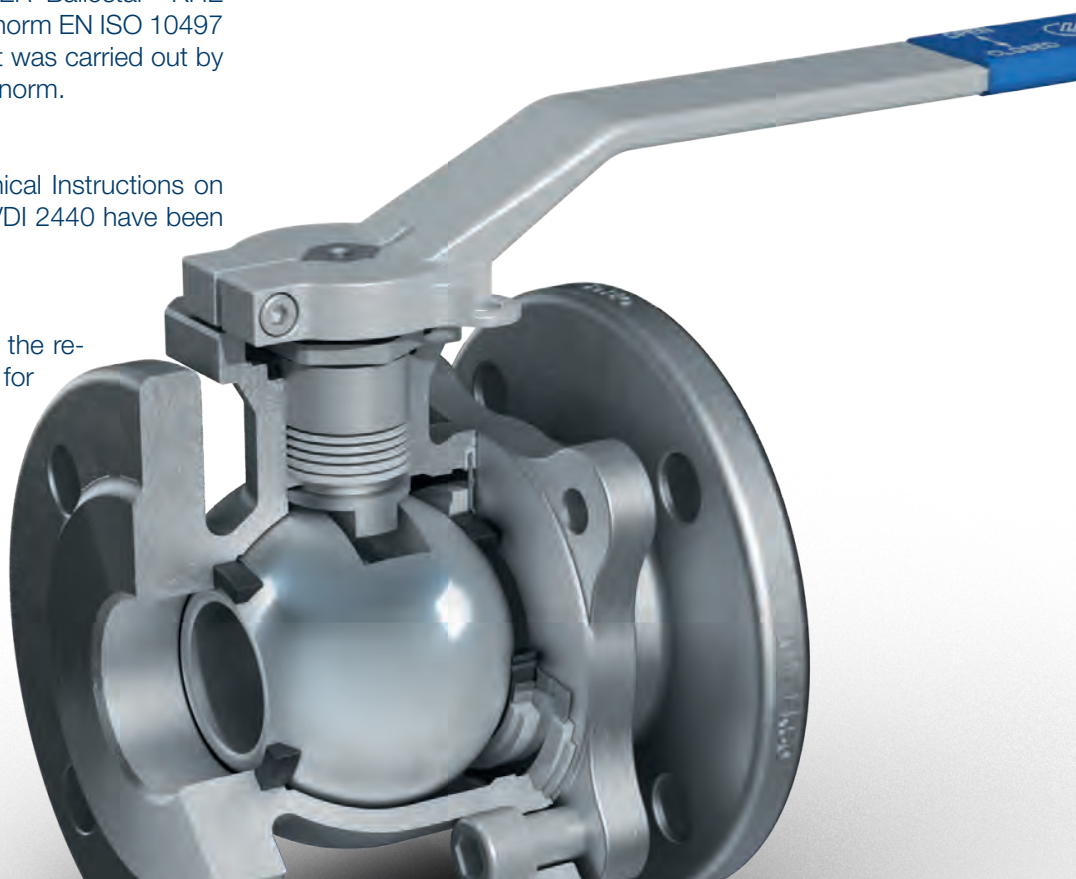

trusted. worldwide.

# BALLOSTAR® KHE

## Overview of types

trusted. worldwide.

### DESIGNS IN ACCORDANCE WITH DIN STANDARDS



**KHE-FK**  
Short flange design



» 08

### DESIGNS IN ACCORDANCE WITH ASME STANDARDS



**KHE-CL**  
Flange design (ASME)



» 09

# BALLOSTAR®

## KHE-FK

### Short flange design

#### GENERAL FEATURES

- » 2-piece ball valve with full bore
- » Floating ball, antistatic, lockable
- » Fire Safe
- » Modular system components

#### CONNECTIONS

Flange in accordance with EN 1092-1 (VIII, Xc)

#### DIMENSIONS

Face-to-face dimensions in accordance with EN 558-1, series 27

#### ACCEPTANCE TESTING

- » Seat leak tightness: EN 12266-1 P12, leakage rate A
- » Tightness to atmosphere: EN 12266-1 P11
- » Strength: EN 12266-1 P10

#### AUTOMATION

Flange connection in accordance with ISO 5211, allows for direct mounting of an actuator or by means of brackets. Pneumatic and electrical actuators utilizable.

#### TEMPERATURE

-60 °C to +300 °C (see pT diagram)

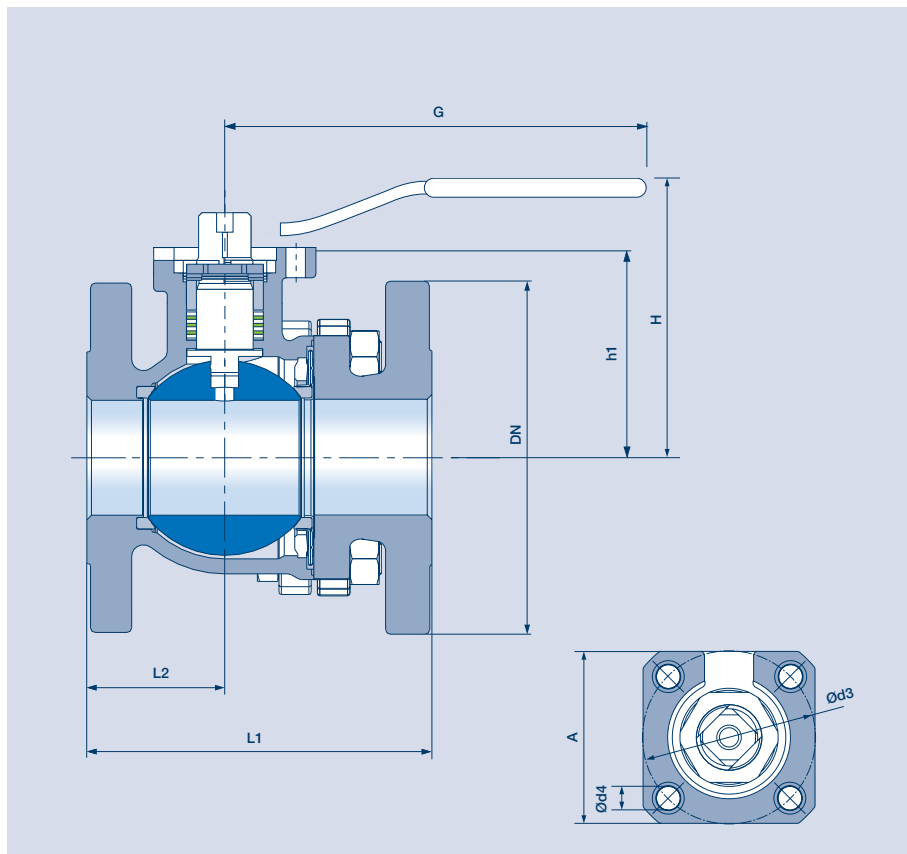

### KHE-FK VARIANTS

DN	Dimensions						PN		Mounting flange for actuator				Weight kg
	L1	L2	H	G	h1	Iz*	VIII	Xc	ISO	A	Ød3	Ød4	
15	115	50	80	132	35	4	40	40	F04	42	42	5.8	2.3
20	120	45	94	162	46	4	40	40	F04	42	42	5.8	3.4
25	125	45	98	162	50	4	40	40	F04	42	42	5.8	4.1
32	130	50	106	252	65	4	40	40	F05	50	50	7	6.2
40	140	50	113	252	72	4	40	40	F05	50	50	7	7.8
50	150	60	131	317	90	4	40	40	F07	70	70	10	11.4
65	170	65	144	317	100	8	40	40	F07	70	70	10	16.2
80	180	65	162	502	122	8	40	40	F10	102	102	12	23.9
100	190	75	176	502	135	8	40	40	F10	102	102	12	31.6
125	325	125	211	652	175	8	40	40	F12	125	125	15	64
65	170	65	144	315	100	4	16	16	F07	70	70	10	16.2
100	190	75	176	500	135	8	16	16	F10	102	102	12	31.6
125	325	125	211	650	175	8	16	16	F12	125	125	15	64
150	350	140	234	650	195	8	16	16	F12	125	125	15	62.7
200	400	165	300	650	236	12	16	16	F12	140	125	15	99.8

#### PRESSURE RANGE PN 40

Material: Steel casting 1.0619 (Material code VIII)  
Stainless steel casting 1.4408 (Material code Xc)

#### PRESSURE RANGE PN 16\*\*

Material: Steel casting 1.0619 (Material code VIII)  
Stainless steel casting 1.4408 (Material code Xc)

\* Number of bores

\*\* In accordance with the norm, the flange face-to-face dimensions of the nominal pipe sizes DN 15-50 as well as DN 80 are the same for PN 16 and PN 40 variants.

# BALLOSTAR® KHE-CL

## Flange design (ASME)

### GENERAL FEATURES

- » 2-piece ball valve with full bore
- » Floating ball, antistatic, lockable
- » Fire Safe
- » Modular system components

### CONNECTIONS

Flange in accordance with ASME B16.5 (VIII, Xc)

### DIMENSIONS

Face-to-face dimensions in accordance with ASME B16.10

### ACCEPTANCE TESTING

- » Seat leak tightness: EN 12266-1 P12, leakage rate A
- » Tightness to atmosphere: EN 12266-1 P11
- » Strength: EN 12266-1 P10

### AUTOMATION

Flange connection in accordance with ISO 5211, allows for direct mounting of an actuator or by means of brackets. Pneumatic and electrical actuators utilizable.

### TEMPERATURE

-60 °C to +300 °C (see pT diagram)

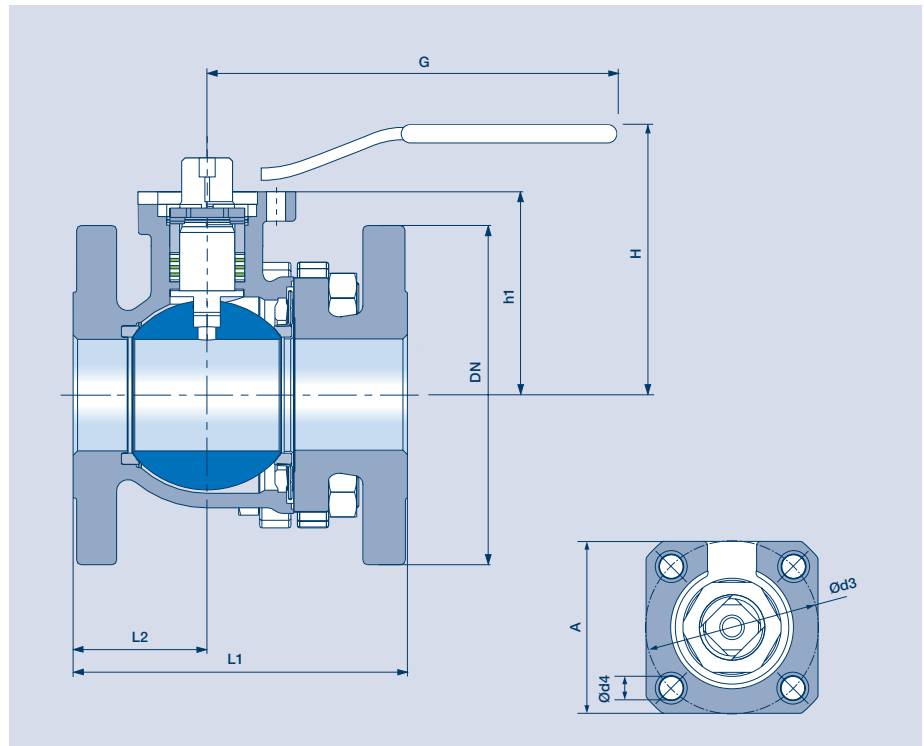

## KHE-CL VARIANTS

### PRESSURE RANGE CLASS 150

Material: Steel casting 1.0619  
(Material code VIII)  
Stainless steel casting 1.4408  
(Material code Xc)

NPS	Dimensions						Class		Mounting flange for actuator				Weight kg
	L1	L2	H	G	h1	Iz*	VIII	Xc	ISO	A	Ød3	Ød4	
1/2"	108	43	81	130	35	4	150	150	F04	42	42	5.8	1.6
3/4"	117	42	95	160	46	4	150	150	F04	42	42	5.8	2.5
1"	127	47	98	160	50	4	150	150	F04	42	42	5.8	3.3
1 1/2"	165	64	114	250	72	4	150	150	F05	50	50	7	7.0
2"	178	60	131	315	90	4	150	150	F07	70	70	10	11.2
2 1/2"	190	66	141	315	100	4	150	150	F07	70	70	10	17.1
3"	203	83	163	500	121	4	150	150	F10	102	102	12	24.3
4"	229	83	176	500	135	8	150	150	F10	102	102	12	34.8
6"	394	184	234	650	195	8	150	150	F12	125	125	15	69.4
8"	457	222	300	650	236	8	150	150	F12	140	125	15	121

# AREAS OF UTILIZATION

Pressure and temperature ranges

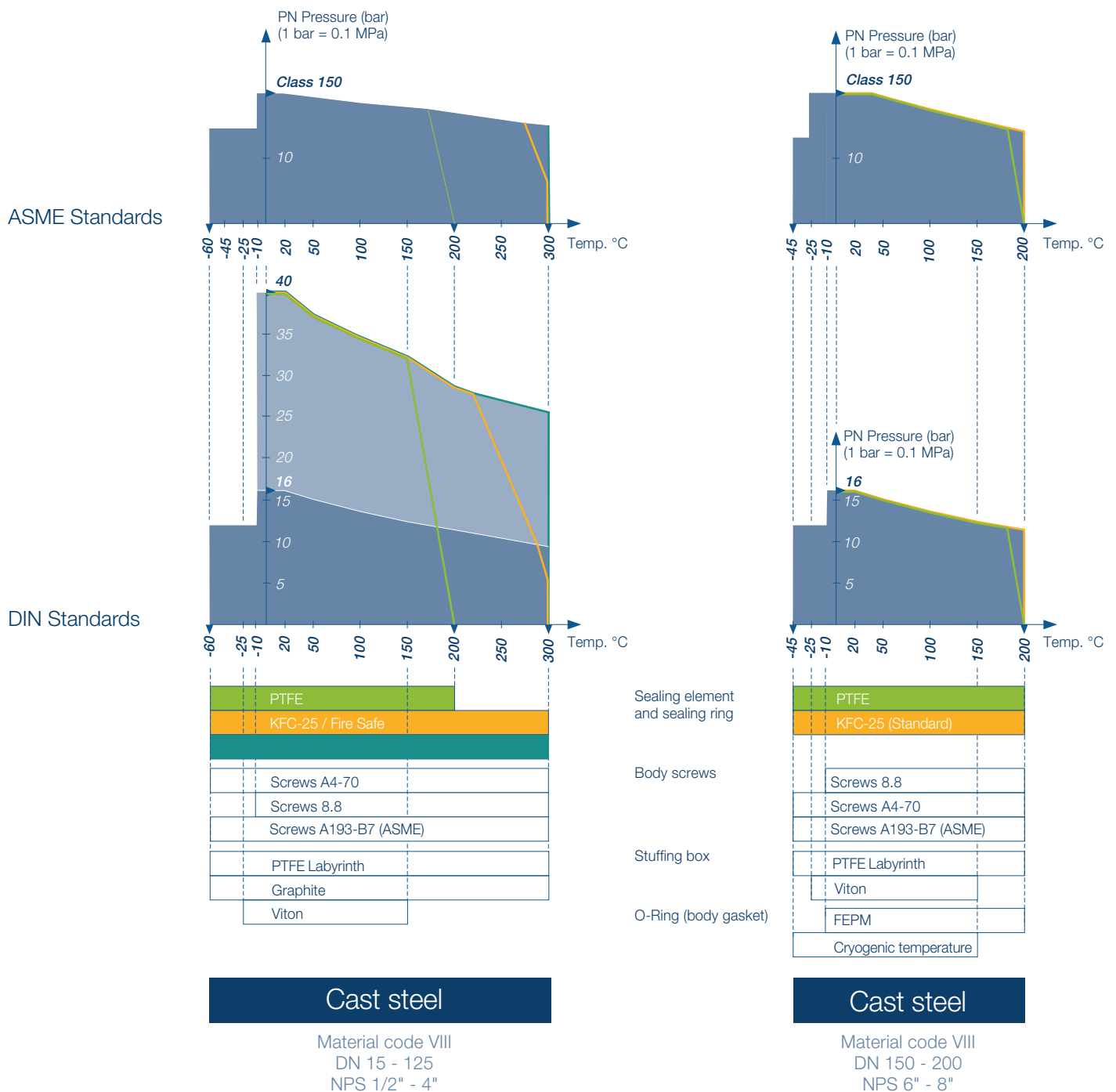

The pT diagrams show the influence of the body materials, sealing materials and operating stems on the area of application of the ball valve.

With these, we offer you safety at the highest level. Insert your operating point into the diagram fields and you will be able to determine whether your safety reserves meet your requirements.

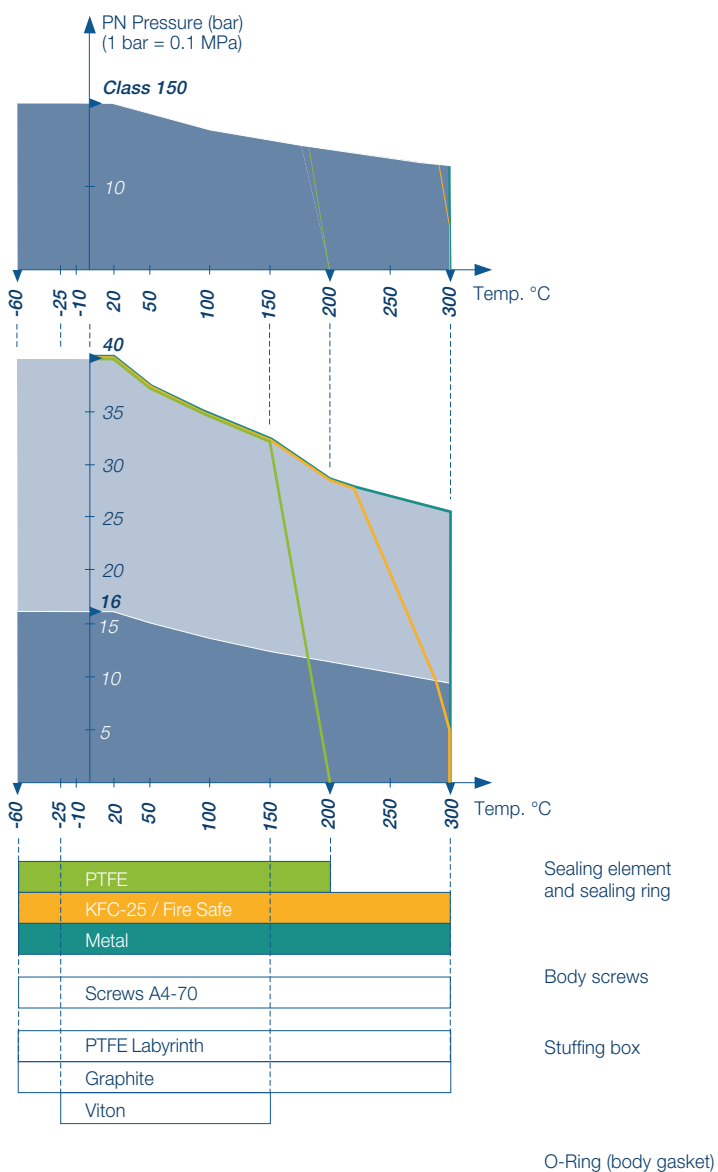
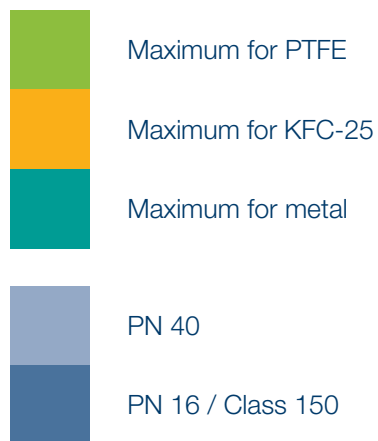

**Stainless steel casting**

Material code Xc  
 DN 15 - 125  
 NPS 1/2" - 4"

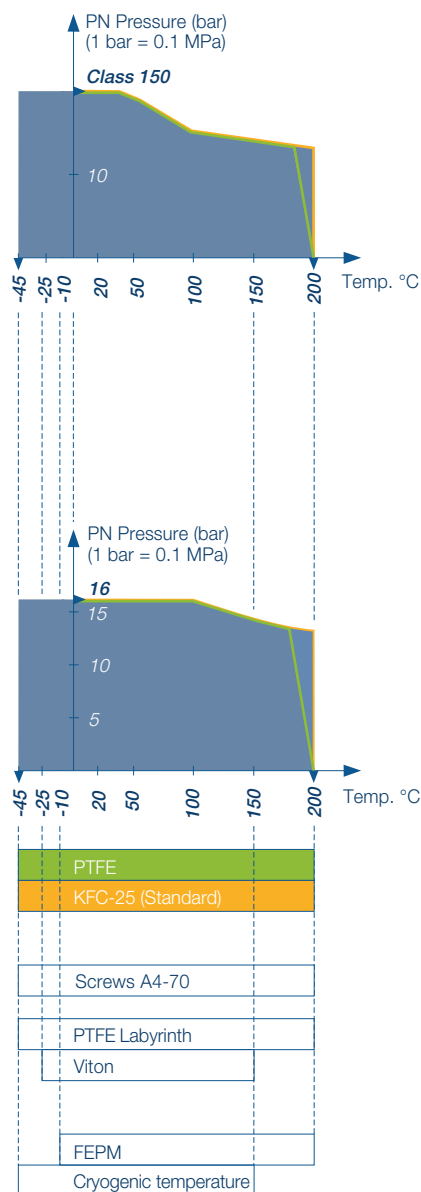

**Stainless steel casting**

Material code VIII  
 DN 150 - 200  
 NPS 6" - 8"

# AREAS OF UTILIZATION

## Stuffing boxes

As a standard, KHE ball valves are fitted with a PTFE Labyrinth stuffing box and a KFC-25 sealing element / ring. The remaining designs listed below can optionally be requested upon order.

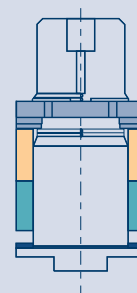
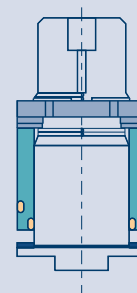
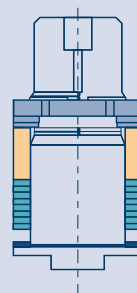

		LABYR. PTFE Labyrinth	VIT. Viton*	GRAPH. Graphite Labyrinth
<b>Media</b>	Water / hot water	Recommended	Not recommended	Recommended
	Mineral oil	Recommended	Recommended	Recommended
	Heat-transfer oil	Not recommended	Not recommended	Recommended
	Liquid gas / cryogenic temperature	Recommended	Not recommended	Less suitable
	Saturated steam	Recommended	Not recommended	Less suitable
	Misc. gases	Not recommended	Recommended	
	Vacuum / full vacuum	Recommended	Recommended	Not recommended
	Hot steam (max. 300 °C)	Not recommended	Not recommended	Recommended
<b>Operating conditions</b>	Standard application	Recommended		
	High number of cycles	Recommended	Recommended	Not recommended
	Frequent temperature changes	Recommended	Not recommended	Recommended
	Application across a wide temperature range	Less suitable	Not recommended	Recommended
	Chemical industry	Recommended	Not recommended	Recommended
	Abrasive media	Recommended	Not recommended	Not recommended
<b>Approvals and Certifications</b>	EN 13774		+	
	EN 14141		+	
	Fire Safe EN ISO 10497	+		
	VDI 2440	+	+	



# ACTUATOR SELECTION

## Actuation torque for the various seals

Nominal diameter DN		Differential pressure (bar)								
		0	5	10	16	Class 150	25	30	40	Class 300
inch	mm	Torque (Nm)								

For standard computations regarding the actuator design, KLINGER recommends the factor 1.5, i.e. using plus 50 %.

### KFC-25

1/2"	15	6	6.2	6.4	6.6	6.8	7	7.2	7.6	8
3/4"	20	12	12.4	12.7	13.1	13.4	13.8	14.1	14.8	15.5
1"	25	14	15	16.1	17.3	18.1	19.2	20.2	22.3	24.3
1 1/4"	32	17	18.4	19.9	21.6	22.7	24.1	25.6	28.4	31.3
1 1/2"	40	25	27.8	30.6	33.9	36.1	38.9	41.7	47.2	52.8
2"	50	37	40.6	44.3	48.6	51.5	55.1	58.8	66	80
2 1/2"	65	60	66.23	72.5	80	85	91.3	97.5	110	200
3"	80	96	114	132	153.6	168	186	204	240	300
4"	100	160	183.8	207.5	236	255	278.8	302.5	350	420
5"	125	270	317.5	365	422	460	507.5	555	650	
6"	150	330	400	450	520	570				
8"	200	485	590	660	760	830				

### PTFE

1/2"	15	5.4	5.6	5.8	6	6.1	6.3	6.5	6.4	7.2
3/4"	20	10.8	11.1	11.4	11.8	12.1	12.4	12.7	13.3	14
1"	25	12.6	13.5	14.5	15.6	16.3	17.2	18.2	20	21.9
1 1/4"	32	15.3	16.6	17.9	19.4	20.4	21.7	23	25.6	28.2
1 1/2"	40	21.3	23.6	26	28.8	30.7	33.1	35.4	40.1	44.9
2"	50	30.3	33.3	36.3	39.9	42.2	45.2	48.2	54.1	75
2 1/2"	65	51	56.3	61.6	68	72.3	77.6	82.9	93.5	180
3"	80	72	85.5	99	115.2	126	139.5	153	180	250
4"	100	120	137.8	155.6	177	191.3	209.1	226.9	262.5	350
5"	125	202.5	238.1	273.8	316.5	345	380.6	416.3	487.5	
6"	150	248	300	338	390	428				
8"	200	364	443	495	570	623				

### METAL

1/2"	15	7.5	7.8	8.2	8.5	8.8	9.1	9.5	10.1	10.8
3/4"	20	15	15.7	16.4	17.2	17.8	18.5	19.2	20.6	22
1"	25	18	19.4	20.9	22.6	23.7	25.1	26.6	29.4	32.3
1 1/4"	32	25	26.7	28.3	30.3	31.7	33.3	35	38.3	41.7
1 1/2"	40	40	44.8	49.5	55.2	59	63.8	68.6	78.1	87.6
2"	50	55	64.4	73.8	85	92.5	101.9	111.3	130	180
2 1/2"	65	85	101.9	118.8	139	152.5	169.4	186.3	220	300
3"	80	140	172.5	205	244	270	302.5	335	400	500
4"	100	250	293.8	337.5	390	425	468.8	512.5	600	750
5"	125	450	580	710	866	970	1,100			

# TECHNICAL DETAILS

Flow characteristics for the determination of the nominal diameter

## SIZE OF BALL VALVE

Flow rate	$Q$	in m <sup>3</sup> /h
Pressure loss	$\Delta p$	in bar
Density	$\rho$	in kg/m <sup>3</sup>
Velocity	$w$	in m/s
Flow coefficient	$K_v$	in m <sup>3</sup> /h
Pressure loss coefficient	$\zeta$	

Allows for the calculation of:

$$K_v = Q * \sqrt{\frac{\rho}{1000 * \Delta p}}$$

The valve is to be selected in a manner that the  $K_v$ -value is greater, or the  $\zeta$ -value less than the computed value.

or

$$\zeta = \frac{2 * \Delta p * 10^5}{\rho * w^2}$$

## FLOW VALUES

DN (mm)	NPS (inch)	$\zeta$	$K_{vs}$ -value
15	1/2"	0.23	18.8
20	3/4"	0.20	35.8
25	1"	0.14	66.8
32	1 1/4"	0.12	118
40	1 1/2"	0.11	193
50	2"	0.10	316
65	2 1/2"	0.076	607
80	3"	0.067	980
100	4"	0.058	1,645
125	5"	0.051	2,742
150	5"	0.045	4,203
200	5"	0.038	8,131

$$\Delta p = \zeta * \frac{\rho}{2} * w^2 * 10^{-5}$$

or

$$\Delta p = \left(\frac{Q}{K_v}\right)^2 * \frac{\rho}{1000}$$

The characteristic unit for shut-off and control valves is the  $K_v$ -value. The values provided in the table apply to a H<sub>2</sub>O flow medium with a temperature of 5 - 30 °C, a density of 1000 kg/m<sup>3</sup> and a pressure loss of  $p = 1$  bar at the valve.

In metric measurement systems the characteristic unit utilized is the  $K_v$ -value. In countries using inches, the characteristic unit is described by means of the  $C_v$ -value. It provides how many US gal/min of water, at a temperature of 60 °F and with a pressure loss of 1 psi, flow through the valve.

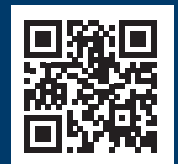

Your KLINGER distribution partner

Edition 2023 | Typing and printing errors reserved

KLINGER Fluid Control GmbH  
Am Kanal 8-10 » 2352 Gumpoldskirchen » Austria  
Tel: +43 2252 600-0 » Fax: +43 2252 600-100  
office@klinger.kfc.at

[www.klinger.kfc.at](http://www.klinger.kfc.at)